

# 20004



07.04.04

## ACMI Screen Lounge project Assembly manual

From Crowd Productions: Assembly, disassembly, maintenance and care of your Screen Lounge pods.

### 01.] Disassembly of a full [four quarter] Screen lounge pod [SLP/4]

A full SLP/4 has 5 main separate structural support elements

- 01 Sub-frame/transporter
- 02 Lower seating wall
- 03 Upper Louvre wall
- 03 Lower *Mantleboot* wall
- 04 Upper TV wall

The SLP/4 has 16 major components that are separated/removed/disassembled in the following order

**01. Soonas.** [One person job.] These are attached to the slatted seat supports with Velcro ties. Each *Soona* has 4 Velcro ties. One at each top corner to hold up the back and one at the base of each side of the back support to pull the back and seating base into the lower lumbar recess. The three *Soonas* can be rolled around each other or stored flat. It is important to store the *Soonas* in clean plastic bags to keep out dirt, stains and moisture.

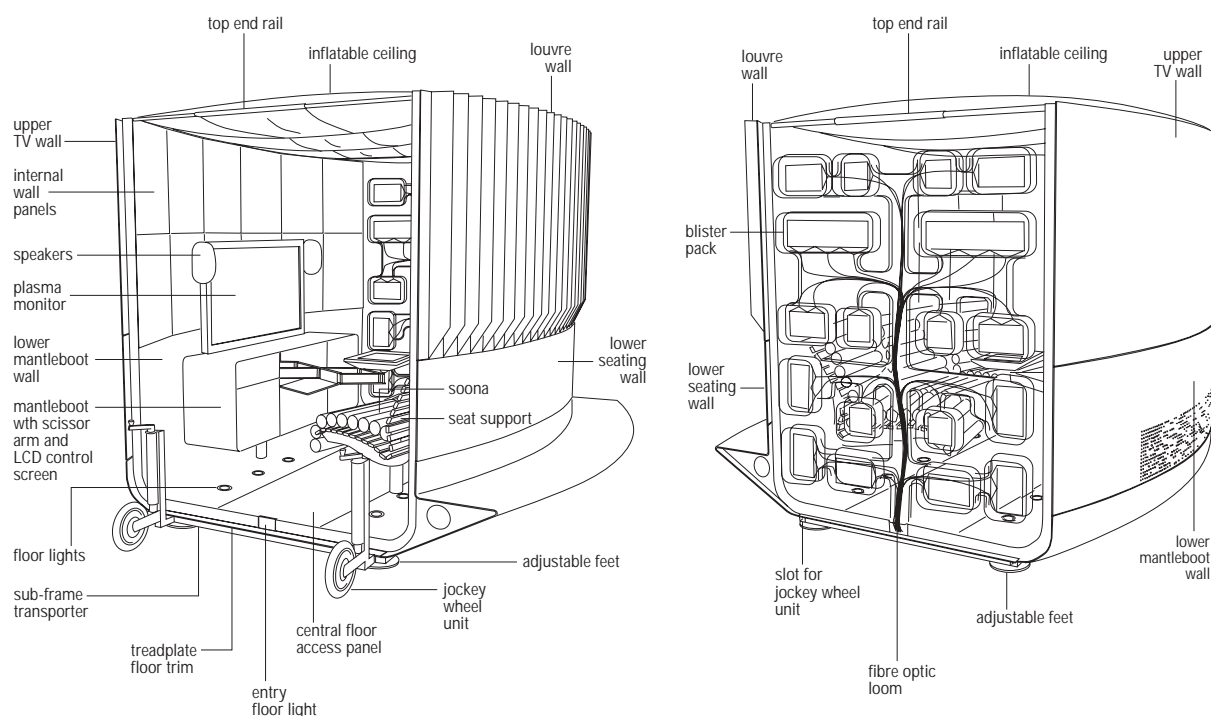

**02. Plasma monitor.** [Two person job.] This is demounted in consultation with Matt Mulchay from ACMI. It is connected to the wall of the Screen Lounge by an AME subframe attached to the back of the Plasma monitor. This locks into an AME frame screwed to supports projecting from the wall of the Screen Lounge. Once the monitor and subframe have been removed, unscrew the AME horizontal support bars from the wall brackets. The monitor must be stored as per instructions from ACMI technicians.

**03. Inflatable ceiling and TV wall rope track.** [Two person job.] The inflatable ceiling must first be deflated. Use a reverse cycle vacuum cleaner to suck the air out. Attach it to the inflation valve mounted on the upper surface of the inflatable ceiling in the back right hand corner. Standing on a tall ladder screw open the valve and depress and rotate the fast release valve in the centre of the mounting. Then apply the mouth of the vacuum cleaner hose and turn it on. When the ceiling has fully deflated, screw valve cover back on. Release the front and rear Velcro end tabs attached to the end top stainless steel rails. The ceiling is secured to the pod along each side by a keder [rope] mounted in a section of aluminium rope track. As the ceiling is wider in the middle than at either ends, one of the rope tracks must be removed to release the ceiling. This must be the rope track above the Plasma monitor and the *Mantleboot*. This rope track is secured by a number of 6mm screws mounted along the top of the TV wall. When removing these screws start at the ends of the pod and move to the centre of the wall. Be careful not to drop the aluminium top trim that sits below the rope track and is secured by the same screws. Carefully lower the rope track and the attached ceiling down into the pod and slide the rope track off out through the front of the pod. Then slide the ceiling out along the rope track guide above the louvre wall, out over the top stainless steel end rail to the front of the pod. One person can stand with their shoes off on the slatted seat base to ease the ceiling keder along the rope track while another person draws the ceiling over the end top rail and onto the floor outside. Once down fold the ceiling into a neat pile and store in a dust proof bag and apply a **warning to avoid any contact with sharp objects** as this will puncture/damage the ceiling.

**04. Centre floor access panel.** [Two person job.] This panel must be removed before the *Blisterpack* is removed. The panel should be lifted from near the centre of the front leading edge being careful not to damage the floor mounted entry light that is recessed into the floor panel along the front edge. Once the front edge of the panel is securely raised up from the floor tray the panel should be pulled

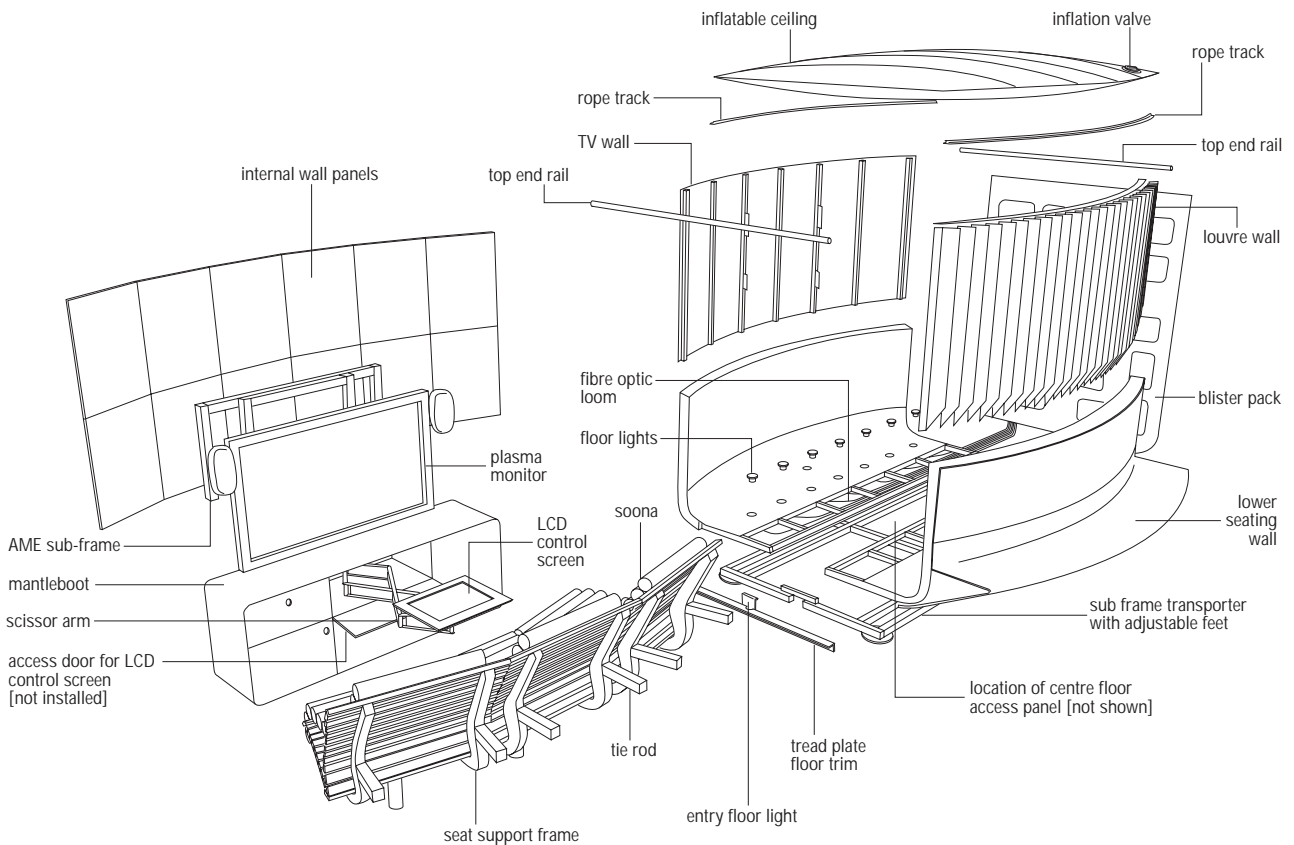

along out of the pod until the second person can hold and lift the trailing edge of the floor panel. Then lift and carry the panel out. In doing this be very careful not to bump, scratch or press against the clear acrylic *Blisterpack* as it will easily crack and the image panels and their securing clips may dislodge.

**05. Blisterpack.** [Six person job.] Before commencing this work all workers must don white gloves to prevent marking the interior surfaces of the *Blisterpack*. The *Blisterpack* is secured to the Screen Lounge by 10 Posi-drive screws encased in pinhead covers. A pinhead tool is required to remove the 10 pinhead covers. Before removing the Posi-drive screws holding up the *Blisterpack* you must first loosen the Fibre Optic cable that connects the *Blisterpack* image lighting to the light driver in the *Mantleboot*. The rear coils of cable must be gently moved towards the *Blisterpack* so that when the *Blisterpack* is lowered to a horizontal position at floor height that there is no additional pressure on the fibres within the *Blisterpack*. A clear area 2.5 meters long by 2.5 meters wide must be prepared adjoining the rear wall of the pod. A very clean, dust free plastic ground sheet must laid onto this floor area and secured in the corners. Remove the Posi-drive screws starting from the bottom. Prior to removing the last screws position four people, two on each side to hold the two skins of the *Blisterpack* together as you lower it into the horizontal position. Use one of the *Blisterlifters* provided to support the centre of the *Blisterpack* as it is lowered into the horizontal position. The *Blisterlifter* should be held horizontally across the *Blisterpack* along the horizontal ridge running halfway up the *Blisterpack*, with one person at each end holding it. Lower the *Blisterpack* shells to the floor, very carefully being sure to avoid dislodging any of the images within the *Blisterpack*. One person needs to be positioned inside the pod carefully controlling the feed of the Optical fibre cable to avoid putting undue pressure on the Optical fibres inside the *Blisterpack*. Once laid out on the ground sheet, lift up the uppermost [internal] Blister shell, using at least 5 people to ensure even support and prevent sagging which will lead to cracking. Carefully carry the shell to a secure vertical storage position and wrap in dust free, clean bubble wrap. Removing this upper shell reveals the images, light guides and Fibre Optic network within the *Blisterpack*.

**06. Blisterpack exhibition/content.** [Two and four person job.] To remove the Fibre optic network and images and light guides, you must wear white gloves. Firstly remove the Fibre optic cables from the image light guides. There are 18 image light guides and approximately 50 cables. Start at the end farthest from the pod. Wrap each image light guide, once disconnected from the cable, in clean dust free bubble wrap and store in a strong container. Do not stack the image light guides as this will damage the clips that hold the image light guides in their respective blisters. The image light guides and their clips [most image light guides have 4 clips] must be handled very carefully as the clips can be knocked from position. As the Fibre optic cable is released from the image light guides it should be straightened out and bound lightly with high quality masking tape to prevent it tangling and breaking. When all the images have been removed, carefully coil up the fibre optic loom and slip it inside a large flat plastic bag. It should be stored away from falling or sharp objects, possibly under the floor of the pod once the treadplate floor trim has been removed.

**07. Treadplate floor trims.** [One person job.] Remove the rear folded treadplate floor trim first. This will release the Fibre optic cable and allow you to curl it around and into the floor cavity of the pod for safe temporary storage. The treadplate floor trim is secure by 4 by 6mm allen key screws along its front face. Repeat this procedure for the front treadplate. Wrap each trim in bubble pack and store.

**08. End top rails.** [Two person job.] The end top rails are secured at either end with an allen key screw on the top surface. This screw secures the rail to a tab at each end, mounted to the wall frame on each side. Once the screws have been removed, the walls can be gently moved apart to release the rail. Pack and store each rail in bubble pack.

**09. Seat support and tie rods.** [Two person job.] The slatted seat support is secured to the pod by three horizontal tie rods radiating from the upper cross bars behind each of the three seats that make up the full seating unit. These tie rods are screwed into the back of the seating cross bars at one end and into recessed threads at the wall surface. Firstly remove the plastic cover from each tie rod. Then loosen off the nuts that secure the tie rod to the seating cross bar, removing the nut completely from the end of the tie rod inside the seat frame. Once these nuts have been removed, the seat can be pulled forward clear of all three tie rods. The tie rods can then be unscrewed from the wall. Then the seat can be lifted from its two recessed mounting points in the floor and carried by two people out of the pod. Take care not to scratch the floor of the pod with the two foot stalks. The seat should be carried by its metal frame where possible and by the slats located in the lumber recess, being careful not to pull any slats away from their mounting screws to the metal frame. Wrap seat in bubble wrap.

**10. Mantleboot.** [To be done in consultation with Crowd Productions.]The Mantle boot contains the computers used to control and interface the Screen Lounge pod to the media platform, the LCD control screen and the retractable scissor arm. The *Mantleboot* must first be emptied of computers by ACMI and PIVoD and the LCD control screen removed by ACMI technicians. The scissor arm should be left in position. **Where ever possible do not remove the *Mantleboot* and leave the body of it attached to the pod chassis.** If the Fibre optic system needs removing please follow these instructions. The fibre optic loom Master Ferrel must firstly be removed from the light diver and carefully slid down the hollow leg/cable access port that it is in. This Master ferrel must be carefully stored in the floor cavity under the pod. [Note: It may be necessary to raise the pod up on its jockey wheels to achieve the necessary clearance under the pod frame to do this. See section on jockey wheels]. The Fibre optic loom must be handled very carefully as the fibres will snap if subjected to too tight a radius. Remove all the doors of the Mantleboot by unclipping them at the hinge point and wrap them in bubble pack for storage. Should the *Mantleboot* body need to be removed for any reason please consult with Crowd Productions.

**11. Internal wall panels.** [One person job.] The internal wall panels are all clipped to support straps inside the frame of the walls. Each panel has a different size and location. They are not interchangeable so it is critical to note the location of each one prior to removal. Start at the centre with the top row of panels. Each panel must be lifted up and out to remove it. The upper end panels need to be slid inwards towards the centre of the wall to clear the tabs that hold the end top rails. The panels once removed must be stored face to face to prevent tearing, gouging or damage to the upholstered surface and wrapped in plastic and bubble wrap to keep out dust and avoid edge damage. There are two rows of panels on each wall, each row contains 6 panels.

**12. Louvre wall.** [Four person job.] When doing this it is advisable to put the centre floor panel back in place to make movement in the pod easier and prevent any damage to the optical fibre loom sitting below the floor cavity. Once the internal panels have been removed the internal frame and all fixing points on the upper frame support structures are revealed. The louvre wall is very heavy and this operation requires 4 people minimum to execute. The louvre wall is connected to the lower wall [the seating wall] by 12x8mm bolts that connect it to the top plate of the seating wall through an aluminium spacer. Remove the outermost bolt first and work in to the centre. Once all 12 bolts have been removed, the wall should be carefully rotated through 90 degrees about its centre so the it is at right angles to the lower wall on which it is sitting at its centre. Lower the wall with the louvers facing upwards so that one person can carry the outer end of the wall free of the pod. It should be lowered onto and moved on a piano trolley and stored in bubble wrap. **Do not lift it by the louvers.**

**13. TV wall.** [Four person job.] When doing this it is advisable to put the centre floor panel back in place to make movement in the pod easier and prevent any damage to the optical fibre loom sitting below the floor cavity. Once the internal panels have been removed the internal frame and all fixing points on the upper frame support structures are revealed. The TV wall is heavy and this operation requires 4 people to execute. The TV wall is connected to the lower wall [the *Mantleboot* wall] by 12x8mm bolts that connect it to the top plate of the *Mantleboot* wall through an aluminium spacer. Remove the outermost bolt first and work in to the centre. Once all 12 bolts have been removed, the wall should be carefully rotated through 90 degrees about its centre so that it is at right angles to the lower wall on which it is sitting at its centre. Lower the wall with the curve facing upwards so that one person can carry the outer end of the wall free of the pod. Move it on a piano trolley and stored in bubble wrap.

**14. Fibre optic loom.**[One person job.] One end of the Fibre optic loom is threaded into the *Mantleboot* cable duct in the hollow leg closest to the Light Driver and the other end of the loom is connected into the floor lights and the image light guides that are installed in the *Blisterpack*. As mentioned above the end of the Fibre optic loom installed in the Mantleboot should be left insitu. The other end of the loom will be either installed in the floor lights or coiled up in the floor space below the pod. We recommend that the Fibre optic loom ends in the floor lights be left as installed. The remaining Fibre optic loom will be taped to the floor frame and chassis below or bagged up to protect it. We advise that the Fibre optic loom be carefully untaped from the subframe/transporter and from the seating wall chassis. The loom should be carefully secured to the floor of the *Mantleboot* wall so that as this element is moved the Fibre optic loom is not exposed to contact and damage.

**15. Entry floor light.** [one person job]. Prior to disassembling the lower structural components of the Screen Lounge it is necessary to remove the floor mounted entry light. The connecting screws for this item are exposed once the folded treadplate floor trims are removed [see item 07]. Remove the screws to release the orange frosted acrylic cover and the clear acrylic light guide. Then unscrew

the wooden mounting plate below.

**16. Mantleboot wall.** [Four person job.] The *Mantleboot* wall and floor chassis is connected to the Seating wall floor chassis by 12x8mm bolts. These should be removed first. The *Mantleboot* wall and floor chassis is connected to the Sub-frame/transporter by 14x8mm bolts. These are located along the leading edge at the centre of the floor assembly and along the chassis frame under the floor running in parallel with the floor lights. With the fibre optic loom safely secured to the floor panel and separated from the Seating wall floor chassis or the Sub-frame/transporter, carefully lift the Mantleboot floor up and clear of the Sub-frame/transporter base and locate it on wooden blocks 100mm high to prevent damage to the fibre optic loom.

**17. Seating wall.** The Seating wall and floor chassis is connected to the Sub-frame/transporter by 14x8mm bolts. These are located along the leading edge at the centre of the floor assembly and along the chassis frame under the floor running in parallel with the stainless steel floor plugs. Move the Seating wall to the centre of the Sub-frame/ transporter and secure with clamps along the horizontal floor members in contact with Sub-frame/transporter floor at the points of greatest lift. This element becomes the first one that is transported from the site on the transporter.

**18. Sub-frame/transporter and jockey wheel system.** The Sub-frame is the main support chassis for the assembled Screen Lounge pod. By attaching four wheels to this frame, one at each corner, this chassis becomes a transporter or trolley to carry all other components of the pod to and from site. When in place the chassis sits on six adjustable feet that support the entire pod. When assembling or setting up a pod the chassis should be set level with equal support from all six feet. Adjust them accordingly. Each foot has slots bored into the outer rim to provide purchase for extra leverage, when required to adjust the feet where access is difficult. At each side of the front and back rails of the Sub-frame/transporter is a slot, each one designed to take a jockey wheel unit. These are stored on site at ACMI. Each wheel should first be wound up so the bottom of the wheel is in line with the base of the base connecting tube. Then insert each jockey wheel unit into its respective slot. Slide them horizontally into the slots until the triangular upper structure of the unit is close to the slot entrance on the Sub-frame/transporter. The units can be jiggled into position. Once all four are in place all four wheels should be lowered in unison to the same extent. This is done to maintain a square distribution of weight to the chassis through the wheels and avoid unnecessary distortion of the frame. The wheels should be wound down until they are clear of the triangular frame of the unit. This allows the wheels to rotate in the horizontal axis and act as trailing or leading wheels. With this arrangement the first item [the Seating wall] can be moved out from the site onto a loading ramp for delivery by truck or into storage. Each of the large structural elements can in turn be clamped, with appropriate padding to the Sub-frame/transporter in turn and wheeled out.

#### 02.] **Assembly of a full [four quarter] Screen lounge pod [SLP/4]**

Repeat the above steps in reverse order.

#### 03.] **Disassembly of a half or open [two quarter] Screen lounge pod [SLP/2]**

Follow the steps from procedure for Assembly of a full [four quarter] Screen lounge pod [SLP/4] as follows

**01.**

**02.** Please Note: You will first need to remove the black metal mesh covering box that protects the back of the Plasma monitor. This is secured on either side at its base with a small self-tapping screw. Remove and store these and remove the cover. Note that the mesh box is folded down and into the gap between the back of the Plasma monitor and the AME frame. To remove it the mesh box must carefully be lifted up and clear of the AME frame. Note that the Plasma monitor is attached to an AME subframe attached to the *Mantleboot* wall. This fitting does not need to be disassembled. Should you need to disassemble it [When you are converting an open [two quarter] Screen Lounge pod to a full [four quarter] Screen Lounge pod] unscrew the AME frame components [Seek advice from ACMI technicians for this operation]. The remaining two vertical AME support struts can be undone without removing the contents of the *Mantleboot*.

**Additional note.** SLP/2s have stainless steel top plates finishing the upper surfaces of the lower wall sections [*Mantleboot* wall and Seating wall]. It is not necessary to remove these unless you intend to reassemble the pod as a full pod or SLP/4. If this is required

firstly remove the AME plasma monitor bracket attached to the top of the *Mantleboot* wall and the two retaining bolts in the corresponding holes on the Seating wall. The AME plasma monitor bracket can be loosened by undoing the nuts at the base of each leg of the bracket. These nuts are located behind the *Mantleboot* and are accessible only by removing the doors and content of the *Mantleboot*. Once the AME bracket and retaining screws have been removed the stainless steel top plates will need to have their silicon glue bonds broken. Carefully insert a knife between the stainless steel top plate and the top surface of the wall below. Silicon has been used sparingly to secure the stainless steel top plates and it should not require a lot of effort to remove. These stainless steel top plates need to be removed to reveal all of the bolt holes for securing the upper walls to the lower chassis along the principle connecting surfaces. The stainless steel plates have been fitted by Crowd and it is advisable to seek directions from Crowd for this task.

Then follow steps: 04, 07, 09, 10, 14, 15, 16, 17, 18

#### 04.] Assembly of a half or open [two quarter] Screen lounge pod [SLP/2]

Follow the steps as outlined in 03.] in reverse order.

---

